

Design and manufacture of the microwave receiver block of X-band phase array radar

Nguyen Van Hanh^{*}, Dinh Van Truong, Vo Van Phuc,
Vo Xung Ha, Tran Thi Tram, Pham Khac Lanh

Radar Institute, Academy of Military Science and Technology, 17 Hoang Sam, Cau Giay, Hanoi, Vietnam.

^{*}Corresponding author: duchanh191175@gmail.com

Received 10 Jan. 2025; Revised 28 Feb. 2025; Accepted 09 May 2025; Published 25 May 2025.

DOI: <https://doi.org/10.54939/1859-1043.j.mst.103.2025.40-46>

ABSTRACT

The article introduces a method of designing and manufacturing a microwave receiver for an X-band phased array radar station on a purpose-built vessel. The design method uses new generation components, based on survey results, functional analysis, and calculation of parameters of the original block that directly affect the formation of the block's function. The microwave receiver block works according to the principle of super-external deviation, mixing frequency twice; its task is to filter and convert microwave pulses into intermediate frequency pulses 2 to the intermediate frequency amplifier.

Keywords: Phased array radar; Microwave receiver; X-band.

1. INTRODUCTION

Model phased array radars are mainly designed and manufactured overseas. Phased array radar systems are designed to observe, detect and track targets at sea, in the air, including low-flying targets of small size, and at the same time provide target indication data for conjugate equipment. In the world, phased array radars are often designed to operate in the S, C, or X bands. Due to the nature of technological confidentiality, scientific information published related to phased array radar systems mostly stops at functional parameters, without detailed announcements and becomes the technological secrets of the manufacturer. Microwave receivers are important components in phased array radar stations. Existing designs of microwave receivers often have a super-infrared structure, mixer (1 or 2 times); direct frequency conversion receiver; low-frequency intermediate receiver and wideband multichannel receiver [1, 2, 6-8].

This paper presents a calculated method, design and manufacture of the microwave receiver of the X-band phased array radar station according to the principle of super-infrared structure and 2 times mixer; it has the advantages of small noise coefficient and large amplification coefficient, thereby increasing the sensitivity of the receiver and improving the combat-technical features of the radar station.

2. SOLVING PROBLEM

2.1. Operating principle of the microwave receiver block

The microwave receiver block has the task filter and converts microwave pulses into intermediate frequency pulses 2 to the intermediate frequency amplifier. The microwave receiver block includes: 1 noise current amplifier; 1 low noise amplifier (LNA); 1 switching (coordination) 1; 8 frequency discriminators (band-pass filters) BPF1 ÷ BPF8, 1 switching (coordination) 2; 1 microwave converter (mixer 1) and 1 intermediate frequency converter (mixer 2) [3]. The functional diagram of the microwave receiver block is shown in figure 1.

The received signal is a cluster of three microwave pulses with different carrier frequencies. After passing through the antenna and the waveguide divider, it is sent to the low-noise amplifier (input to the receiver). Here, the microwave signal is amplified and sent to the (coordinated) switch 1. For

each group of microwave pulses with different carrier frequencies, the (coordinated) switch 1 will send the microwave signal to the input of 1 of 8 filters (BPF1 ÷ BPF8), the frequency filters (BPF1 ÷ BPF8) only allow 3 frequencies of the transmitter to pass through. The microwave signal after passing through the frequency filter will be sent to the (coordinated) switch 2. Corresponding to each group of microwave pulses with different carrier frequencies, the (coordinated) switch 2 will send the microwave signal from the output of 1 of the 8 filters (BPF1 ÷ BPF8) to the microwave converter (mixer 1). The input of the mixer also has an local oscillator (LO1) signal with the corresponding frequency from the shaper. The mixer 1 mixes the two signals to form the first intermediate frequency signal IF1 (Π1, Π2, Π3). The IF1 signals after being pre-amplified will be sent to the mixer 2 and amplifying again and separated into 3 carrier frequency channels. Going to the IF converter, there are also the 2nd LO signals (LO2 (1), LO2 (2), LO2 (3) - Corresponding to the frequencies Π1, Π2, Π3). At the IF converter (mixer 2), the Π1, Π2, Π3 signals are converted into intermediate frequency signals IF2 (30 MHz) and then sent to the IF amplifier.

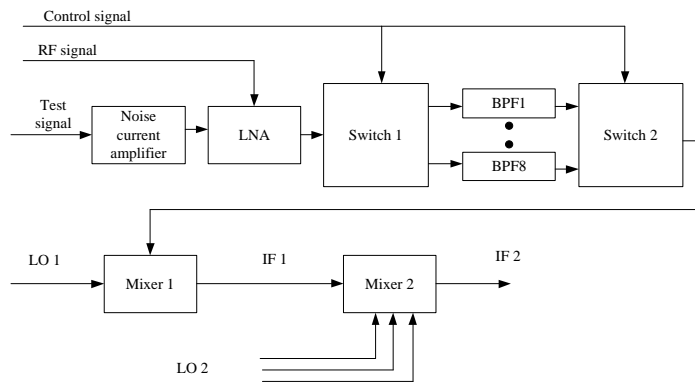

Figure 1. The functional diagram of the microwave receiver block.

2.2. Main technical requirements for the microwave receiver block

2.2.1. Receiver noise [4, 5]

The receiver noise characteristic determines the receiver sensitivity, which is the limit of the smallest RF input power that the receiver can detect. Receiver noise is one of the parameters that mainly affects the detection range of the radar station. The noise factor of an amplifier stage is determined by the signal-to-noise ratio (SNR) of the input and output:

$$F = \frac{SNR_{in}}{SNR_{out}} \text{ [times]} \quad (1)$$

The total noise factor: With the n-stage model, the total noise factor is [Friis formula]:

$$F_T = F_1 + \frac{F_2 - 1}{g_1} + \dots + \frac{F_i - 1}{g_1 g_2 \dots g_{i-1}} + \dots + \frac{F_n - 1}{g_1 g_2 \dots g_{n-1}} \quad (2)$$

where: F_i and g_i are the noise factor and gain of stage i .

An important consequence of formula (2) is that the noise factor of a radar receiver is determined by the first amplifier stage, the subsequent stages have little influence on the noise factor. The noise factor of a radar receiver is:

$$F_{MT} = F_{LNA} + \frac{F_{rest} - 1}{g_{LNA}} \quad (3)$$

where: F_{MT} : Radar receiver noise factor; F_{LNA} : Noise factor of low-noise amplifier; F_{rest} : Total noise factor of downstream stages; g_{LNA} : Gain of low-noise amplifier.

2.2.2. Receiver sensitivity [4, 5]

Receiver sensitivity characterizes the ability to receive weak signals. Receiver sensitivity is the minimum input signal level (RS_{min}) required to produce an output signal level with a given SNR and is defined as RS_{min} times the noise power, see equation (4). The relationship between sensitivity and noise factor is:

$$RS_{min} = SNR_{min}kT_0BF \tag{4}$$

where: k : Boltzman constant = 1.38×10^{-23} , [J/°K]; T_0 : Absolute temperature of receiver input = 290°K, [°K]; B : Receiver bandwidth [Hz]; F : Receiver noise factor, [times].

Or write as dBm:

$$RS_{min}[dBm] = -174 [dBm] + F [dB] + 10lgB + 10lgSNR_{min} \tag{5}$$

From (5), we see that there are two methods to improve the receiver sensitivity, which are: Reducing the noise factor by using a low-noise amplifier; narrowing the receiver bandwidth determined by the width of the received spectrum signal. However, narrowing the bandwidth without distortion is relatively difficult. Thus, in radar receivers, sensitivity and noise factors are closely related when we know the bandwidth of the receiver.

2.3. Calculate and design of the microwave receiver block

2.3.1. Building technical parameters of the microwave receiver block

The problem of designing and manufacturing a new microwave receiver block is based on measuring and surveying the technical parameters of the original microwave receiver block on the phased array radar station. The main technical parameters of the microwave receiver block are listed in table 1. The functional diagram of the modern manufactured receiver block is shown in figure 2.

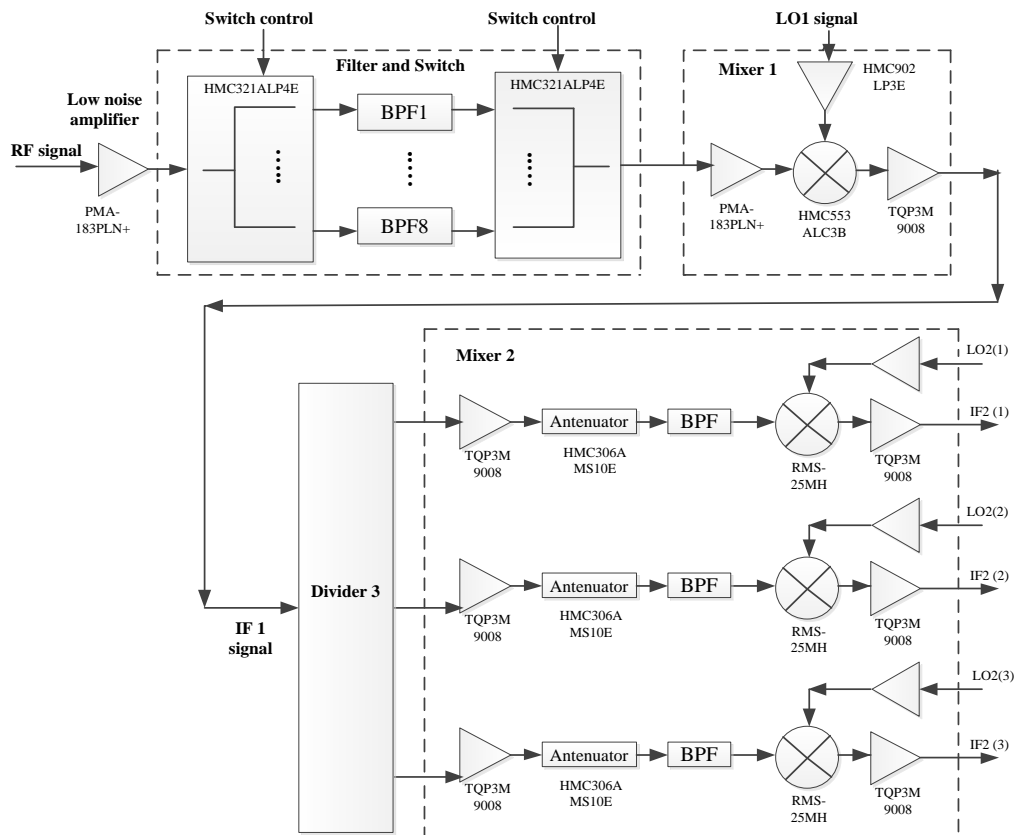

Figure 2. The functional diagram of the new manufactured receiver block.

Table 1. Technical parameters.

Oder	Technical parameters	Requirements
1	Frequency range	$(8220 \div 8880) \pm 1$ MHz
2	LO1 frequency range	$(9100 \div 9620) \pm 1$ MHz
3	LO2 frequency ($\Gamma_1, \Gamma_2, \Gamma_3$)	772, 844, 916 MHz
4	IF1 (Π_1, Π_2, Π_3)	742, 814, 886 MHz
5	IF2	(30 ± 0.5) MHz
6	Receiver noise factor	≤ 3.5 dB
7	Microwave signal image suppression	≥ 50 dB
8	Power supply	$(+6.3 \pm 0.25)$ V; $(+12.6 \pm 0.5)$ V

The input signal from the antenna or test channel is fed to the low noise amplifier (LNA) input using the PMA-183PLN+ LNA to achieve the required signal level. The signal from the LNA output is fed to 1 of 8 BPF via RF switch 1 (1 input, 8 outputs) using the HMC321ALP4E with up to 30 dB channel isolation. The selection of which filter the signal goes to depends on each radio frequency combination and is controlled by 8 parallel bits. The output signals of the filters are fed to RF switch 2 (8 inputs, 1 output) also using the HMC321ALP4E IC. The signal is then fed to mixer 1 (called RF1 signal). Also fed to mixer 1 is LO1. Mixer 1 uses PMA-183PLN+ LNA (RF1 signal amplifier), HMC902LP3E LNA chip (LO1 signal amplifier), HMC553ALC3B mixer and TQP3M9008 amplifier (amplifying the output signal of mixer). The output signal of mixer 1 is sent to the input of mixer 2. Mixer 2 also has 3 extraneous signals 2 (frequency 772 MHz, 844 MHz, 916 MHz). Mixer 2 uses TQP3M9008 amplifier, HMC306AMS10E digital attenuator, RMS-25MH+ mixer, SCA-3-11+ power divider and 3 BPFs (corresponding to 3 receiving channels) BPF-F598+, CBP-804F+, CBP-897G+. RF2 signal to the input of mixer 2 is divided into 3 channels (after passing through SCA-3-11+ chip). At each channel, the signal is amplified and mixed down to the IF 2 (frequency 30 MHz) to the output of the block. HMC306AMS10E digital attenuator adjusts the uniformity of the output power of 3 channels.

2.3.2. Parameter analysis calculation

Table 2 lists the gain and noise coefficients of the component modules based on the datasheet of the components used in the modern manufactured microwave receiver block (with the principle that the components with switching, filtering, dividing and mixing functions have losses, the gain must be reduced by the loss value, i.e. signal attenuation).

Table 2. Gain and noise coefficients of the component modules.

Parameters	LNA	Switch 1	Filter (1÷8)	Switch 2	Mixer 1	Mixer 2
Gain (dB)	+26	-3.1	-6.5	-3.1	PMA-183PLN+: +26 HMC553LC3B: -7 TQP3M9008: +21.7 SCA-3-11+: -6.3 Total: +34.4	TQP3M9008: +22.2 HMC306: -15.5 BPF: -4.5 RMS-25MH+: -8.5 TQP3M9008: +22.2 Total: +15.9
Noise (dB)	1.3	3.1	6.5	3.1	PMA-183PLN+: 1.3 TQP3M9008: 1.1 Total: +2.4	TQP3M9008: 1.1 Total: +1.1

Based on the data in table 2, we can calculate the gain and noise coefficient of the microwave receiver according to the formula (4):

$$F_{MT} = F_{LNA} + \frac{F_{rest}-1}{g_{LNA}} = 1.3 + \frac{16.2-1}{26} = 1.9 \text{ dB}$$

The summary data are shown in table 3. The results show that the noise factor of the microwave receiver is small (1.9 dB), the amplification factor is large (63.6 dB), meeting the technical specifications.

Table 3. Summary of gain and noise figure of microwave receiver.

Parameters	After LNA	Microwave receiver
Gain (dB)	+37.6	+63.6
Noise (dB)	24.7	1.9

3. RESULTS AND DISCUSSION

The test conditions and parameters for setting up the measuring device are as follows:

- + E8267D transmitter creates a RF signal: Transmits a power pulse signal of -70 dBm, the pulse width is 10 μs; the repetition period is 100 μs; the frequency is 1 of the 24 operating frequencies of the station;

- + N5183A transmitter creates a LO1 signal: Transmits a continuous power signal of 2 dBm, the frequency depends on the RF frequency;

- + SMB100B transmitter creates a LO2 signal: Transmits a continuous power signal of -8 dBm, the frequency is one of the frequencies 772 MHz, 844 MHz, 916 MHz;

- + N9322C spectrum analyzer: Measure and test intermediate frequency signals 2.

The image of the newly manufactured microwave receiver block is shown in figure 3a and figure 3b. Some measurement results in the Laboratory are shown in figure 4.



(a)



(b)

Figure 3. Image of modern manufactured receiver block.

The measurement results of the main technical indicators are shown in table 4.

Table 4. Measurement results of main parameters.

Oder	Technical parameters	Requirements	Measurement results
1	Frequency range	(8220 ÷ 8880) ± 1 MHz	(8220 ÷ 8880) MHz
2	LO1 frequency range	(9100 ÷ 9620) ± 1 MHz	(9100 ÷ 9620) MHz
3	LO2 frequency (Γ1, Γ2, Γ3)	772, 844, 916 MHz	772, 844, 916 MHz
4	IF1 (Π1, Π2, Π3)	742, 814, 886 MHz	742, 814, 886 MHz
5	IF2	(30 ± 0.5) MHz	30 MHz
6	Receiver noise factor	≤ 3.5 dB	1.9 dB
7	Microwave signal image suppression	≥ 50 dB	51 dB
8	Power supply	(+6.3 ± 0.25) V; (+12.6 ± 0.5) V	+6.4 V; +12.5V

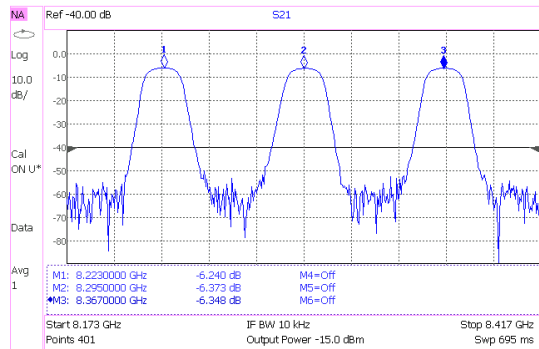

a. Characterise of BPF1;

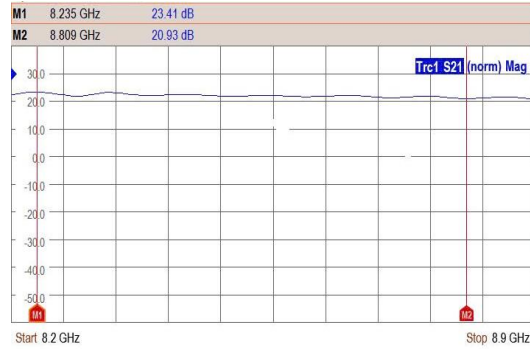

b. Gain measurement results of LNA;

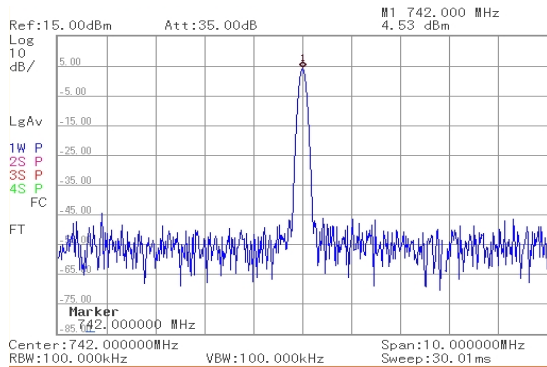

c. IF 1 (first frequency);

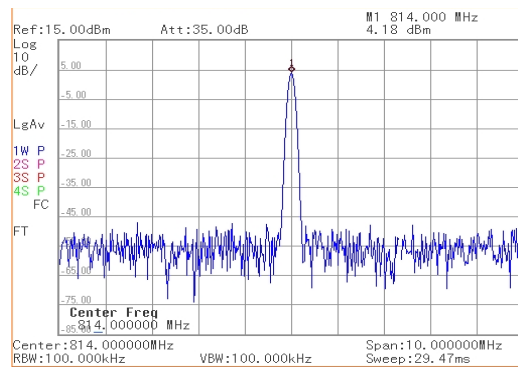

d. IF 1 (second frequency);

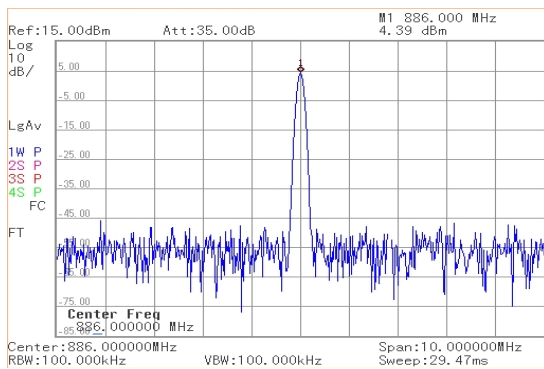

e. IF 1 (third frequency);

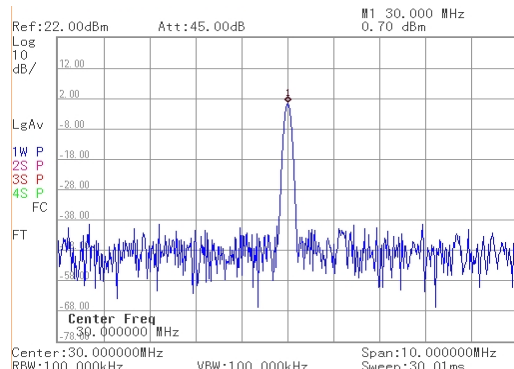

f. IF 2.

Figure 4. Measurement results in the laboratory.

The measurement results of the component modules show that the bandwidth of the BPFs (BPF1 ÷ BPF8) is narrow, reaching from (15 ÷ 17) MHz (figure 4a); the gain of the LNA reaches 23.4 dB (figure 4b) and the entire microwave receiver meets the requirements, especially the noise factor and the gain are both superior to the requirements. The microwave modules (noise current amplifier, low noise amplifier, switching, bandpass filter, frequency mixer) are simulated, designed by ADS (Advanced Design System) microwave circuit design software and manufactured on Roger 4350B strip circuit (dielectric constant 3.66; thickness 0.254 mm). Thanks to the application of advanced design and manufacturing technology, the newly manufactured receiver block has the following advantages compared to the original blocks:

- Materials and manufacturing components are mainly imported from capitalist countries, not dependent on the supply of components from Russia;

- Electronic components ensure high stability and reliability;
- Easy to localize, detect and replace components when damage occurs due to the use of integrated components;
- Using integrated components from capitalist countries, the newly manufactured blocks consume less power than the original blocks from Russia.

4. CONCLUSIONS

The microwave receiver block of the X-band phased array radar station has been measured in the laboratory and installed and tested on purpose-built vessels. The resulting block has the same function as the original block and meets the technical requirements of the X-band phased array. In addition, the block is designed based on new-generation components, commonly used today, so it can be replaced and repaired when necessary, which cannot be done on the original block. The successful design and manufacture of the microwave receiver block allows for an increase in the receiver sensitivity (due to the small noise factor and large amplification factor), while improving the technical features of the phased array radar station. The obtained results can be extended to the above phased array radar stations in other frequency bands, such as S, C.

REFERENCES.

- [1]. Nguyễn Thị Ngọc Minh, Lê Ngọc Uyên, Nguyễn Văn Hạnh, "*Cải tiến và bán dẫn hoá tuyến thu cao tần đài ra đa II-37*", Tạp chí Nghiên cứu KHKT & CNQS số 22, tr. 165-171, (2008), (in Vietnamese).
- [2]. Nguyễn Thị Ngọc Minh, Nguyễn Văn Hạnh, Trần Mạnh Quý, Trần Thị Trâm, "*Một số giải pháp kỹ thuật áp dụng trong thiết kế chế tạo máy thu đa kênh của đài ra đa Cộng hưởng-VN*", Tạp chí Nghiên cứu KH & CNQS- Tuyển tập các Báo cáo Khoa học Hội nghị KH Ra đa năm 2011, tr. 153-161, (2011), (in Vietnamese).
- [3]. "A 16-element phased-array receiver with beam scanning for advanced automotive radars", IEEE Transactions on Microwave Theory and Techniques 62 (11):2823-2832, (2014).
- [4]. Merrill L.Skolnik, "*Chapter 6: Radar receivers*", Radar Handbook, Third Edition, The McGraw-Hill Companies, (2008).
- [5]. Peng Yan, Eero Mõki-Esko, Mikko Valkama, and Markku Renfors, "*Receiver architectures*", Department of Communications Engineering, Tampere University of Technology, Finland, (2010).
- [6]. Ioannis Kassotakis, "*Modern radar techniques for air surveillance & defense*", Journal of Computations & Modelling, vol.4, no.1, 2014, 189-205 ISSN: 1792-7625 (print), 1792-8850 (online) Scienpress Ltd, (2014).
- [7]. Rahul Sadhu, "*Design and implementation of modern X band Up/Down converter*", IEEE Xplore, (2022).
- [8]. Joseph A. Bruder, "*Principles of modern radar, chapter 11 radar receivers*", p. 391–416, (2024).

TÓM TẮT

Thiết kế, chế tạo khối máy thu siêu cao tần của đài ra đa mạng pha băng X

Bài báo giới thiệu về một phương pháp thiết kế, chế tạo máy thu siêu cao tần của đài ra đa mạng pha băng X trên tàu chuyên dụng. Phương pháp thiết kế sử dụng các linh kiện thể hệ mới, dựa trên kết quả khảo sát, phân tích chức năng, và tính toán các tham số của khối nguyên bản có ảnh hưởng trực tiếp đến việc hình thành nên chức năng của khối. Khối máy thu siêu cao tần làm việc theo nguyên lý siêu ngoại sai, trộn tần 2 lần; có nhiệm vụ lọc, biến đổi các xung siêu cao tần thành các xung trung tần 2 đưa đến bộ khuếch đại tần số trung gian.

Từ khóa: Ra đa mạng pha; Máy thu siêu cao tần; Băng X.