

Study on the effect of rotating shaped charge liner material on penetration depth using the SPH numerical simulation method

Bui Xuan Son, Phung Van Cuong*, Do Van Minh, Hoang Van Cuong, Dang Hong Duy

Faculty of Weapons, Le Quy Don Technical University, 246 Hoang Quoc Viet, Dong Ngac, Hanoi, Vietnam.

*Corresponding author: cuongmta41ctd@gmail.com

Received 8 Apr. 2025; Revised 10 Jul. 2025; Accepted 10 Aug. 2025; Published 25 Aug. 2025.

DOI: <https://doi.org/10.54939/1859-1043.j.mst.105.2025.163-170>

ABSTRACT

In this paper, the effect of liner material on the penetration capability of rotating shaped charge warheads was investigated. The authors employed 3D simulations using the Smoothed Particle Hydrodynamics (SPH) mesh-free method in Ansys Autodyn to study the influence of liner materials on rotating shaped charge warheads. The subject of study is a 40 mm caliber shaped charge warhead, with two liner material options: copper and steel. The numerical simulations were conducted at different rotational speeds about the warhead's axis of symmetry: non-rotating, 2000 rpm, 4000 rpm, 6000 rpm, 8000 rpm, 10000 rpm, 12000 rpm, and 14000 rpm. The simulation results indicate that as rotational speed increases, the penetration depth into steel decreases. Copper liners exhibit superior steel penetration compared to steel liners. However, when the rotational speed reaches 10000 rpm, the penetration depth of the copper-lined warhead is not significantly greater than that of the steel-lined warhead. This research method can be applied to optimize the structural design of rotating shaped charge warheads.

Keywords: 40 mm rotating shaped charge warhead; Penetration capability of shaped charge warheads; SPH method.

1. INTRODUCTION

The key mechanical properties of liner materials that significantly affect the penetration depth of the shaped charge jet are ductility, density, and strength. Higher ductility allows for better jet elongation, resulting in a longer jet and deeper penetration. Similarly, a higher density leads to greater penetration depth. Based on these principles, copper is superior to steel in terms of both ductility and density. Therefore, when using a copper liner, the penetration capability of the shaped charge jet is generally higher than that of a steel liner. Since higher density increases the mass of the jet formed from each liner element, the jet maintains its integrity better, allowing for greater elongation and ultimately deeper penetration [12].

However, when the projectile's rotational velocity is high, the penetration depth of a shaped charge with a copper liner is not significantly greater than that of a shaped charge with a steel liner. This is because, under these conditions, the jet experiences twisting and potential fragmentation, reducing its length and penetration capability. To optimize material usage and reduce costs (especially for expensive materials like copper), steel liners are often used in such cases, particularly for medium-caliber rotating shaped charges that stabilize based on gyroscopic principles [12, 13].

Several factors affect the penetration capability of shaped charge warheads, including wave shapers, explosive types, liner geometry, and standoff distance. However, there have been few studies on the effect of warhead rotation around its axis of symmetry. Both theoretical and experimental research indicate that rotational velocity negatively impacts jet formation and penetration. When the warhead rotates, the jet also acquires rotational motion. Due to differences in linear velocity between the jet's tip and tail, their rotational speeds also differ. This velocity gradient, combined with centrifugal forces, causes the jet to twist, undergo tensile rupture, and lose structural integrity, ultimately reducing its penetration effectiveness [12, 13].

Currently, studies on shaped charge warhead effectiveness often rely on numerical simulations using software such as Ansys, Abaqus, and LS-DYNA. A common approach involves using an Eulerian 2D solver to model the entire process from detonation initiation to complete jet formation, followed by a Lagrangian 2D solver to simulate the jet penetration process. However, simulating the penetration performance of rotating shaped charge warheads in 2D is highly challenging. To address this, the mesh-free Smoothed Particle Hydrodynamics (SPH) method in Ansys is used for 3D simulations of rotating warheads.

SPH is a mesh-free computational method used for simulating problems involving large deformations, free-surface flows, high-impact events, and material failure. Within Ansys LS-DYNA, SPH is primarily applied to impact, explosion, cutting, and fluid flow problems [6-8].

Based on the SPH method in Ansys, the authors conducted a study on a 40 mm caliber shaped charge warhead, examining the effect of liner materials on the penetration capability of rotating warheads at various rotational speeds.

2. SIMULATION MODEL

2.1. Geometric model of the problem

The geometric model under investigation consists of a 40 mm caliber shaped charge warhead and a steel target with dimensions $\Phi \times L = 60 \times 100$ mm, as illustrated in figure 1 below:

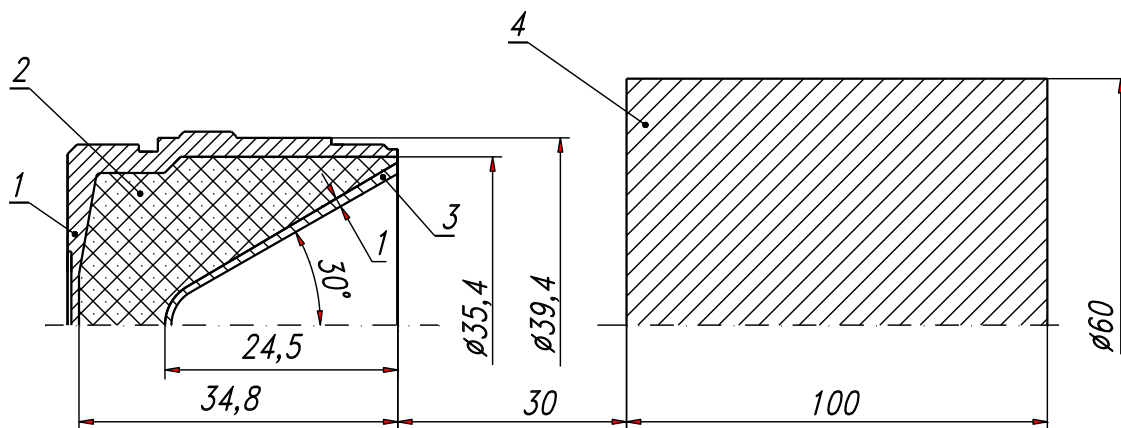

Figure 1. Research model:

1. Casing; 2. Explosive; 3. Liner; 4. Target.

The investigated shaped charge warhead consists of three main components: casing, liner, and explosive. The warhead has a rotationally symmetric shape, and throughout the study, the geometric dimensions and material properties of the casing, explosive, and target are kept constant. Only the liner material (copper or steel) and the rotational velocity of the warhead around its axis of symmetry are varied to evaluate their impact on the penetration capability of the rotating shaped charge. The 40 mm caliber shaped charge warhead model, when tested statically (non-rotating) for penetration depth, achieved a result of approximately 80 mm. The liner was made of M1-grade copper, the explosive used was A-IX-1, and the target material was 40X steel.

The study employs the SPH (Smoothed Particle Hydrodynamics) method in Ansys Autodyn to simulate the entire process, from detonation initiation to the full formation of the shaped charge jet, as well as the interaction between the jet and the steel target. The particle size is set to 0.4 mm, and the computation time for each simulation scenario ranges from 12 to 72 hours.

2.2. Material model in the simulation

2.2.1. Explosive material model

Based on the equivalence between the actual materials used in the shaped charge warhead and those available in the Ansys material library, the explosive used in the simulation model is Comp B [4].

Table 1. Parameters of the JWL equation of state for Comp B explosive.

ρ_0 (kg/m ³)	D (km/s)	A (Gpa)	B (Gpa)	R_1	R_2	ω
1.717	7.98	524.2	7.678	4.20	1.10	0.34

2.2.2. Material model for casing, liner, and target

Based on the equivalence between the actual materials used in the shaped charge warhead and those available in the Ansys material library, the materials for the casing, liner, and target are selected as follows:

Casing Material: Aluminum AL 6061-T6. This material undergoes significant deformation under the pressure of detonation products. Therefore, the Shock equation of state (EOS) is used to model the casing material.

The liner material was considered in two cases: CU-OFHC2 copper and STEEL 4340. CU-OFHC2 is a high-purity copper with a purity greater than 99.99%, while STEEL 4340 is a low-alloy high-strength steel.

The target material, as defined in the Ansys material library, is STEEL 1006, which is a low-carbon steel.

The parameters for the Shock EOS and the Johnson-Cook strength model for these materials are provided in tables 2 and 3 [1] below.

Table 2. Shock equation of state parameters for materials.

No.	Material name	ρ_0 (g/cm ³)	Γ	$C1$ (cm. μ s ⁻¹)	S1	$C2$ (cm. μ s ⁻¹)	S2	$\frac{VB}{v_0}$
1	AL 6061-T6	2.703	1.97	0.5240	1.4	0	0	0
2	STEEL 1006	7.896	2.17	0.46	1.49	0	0	0

Table 3. Johnson-Cook strength model parameters for materials.

No.	Material name	ρ_0 (g/cm ³)	A (Mbar)	B (Mbar)	C	n	m	T_{nc} (K)
1	STEEL 1006	7.896	0.00275	0.0035	0.022	0.36	1	1811
2	STEEL 4340	7.830	0.00792	0.0051	0.014	0.26	1.03	1793
3	CU-OFHC2	8.960	0.00292	0.0009	0.025	0.31	1.09	1355

3. RESULTS AND DISCUSSION

To investigate the effect of liner material on the penetration capability of the rotating shaped charge warhead, simulations were conducted using Ansys Autodyn, specifically the SPH module, in 8 scenarios. These scenarios correspond to the warhead rotating around its axis with the following rotational speeds: 0 rpm (non-rotating), 2000 rpm, 4000 rpm, 6000 rpm, 8000 rpm, 10000 rpm, 12000 rpm and 14000 rpm. These rotational speeds are equivalent to angular velocities of 0 rad/s, 209 rad/s, 419 rad/s, 628 rad/s, 838 rad/s, 1047 rad/s, 1257 rad/s, and 1466 rad/s. The simulation results for the interaction with the steel target at 0.1 ms for each type of liner material are provided in tables 4 and 5. The simulation images exclude the casing and explosive visuals.

Table 4. Simulation results of the jet formation process interaction with steel target.

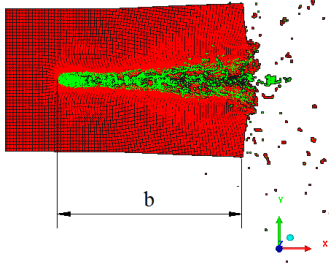
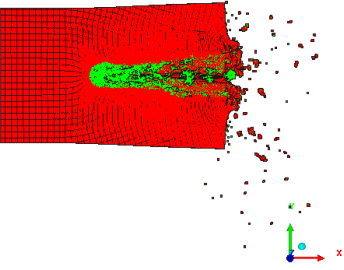
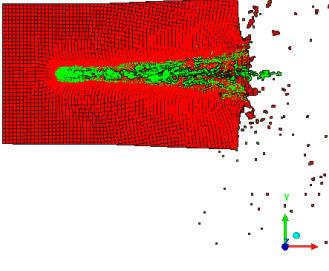
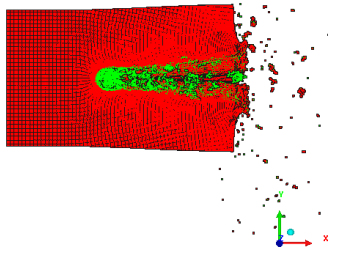
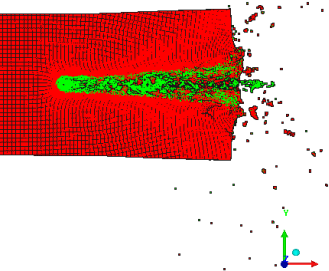
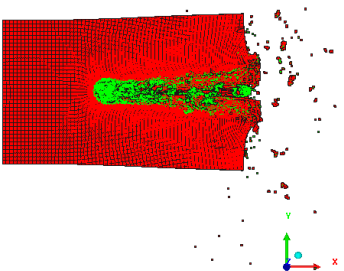
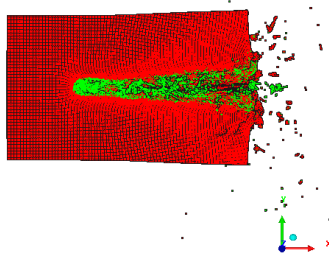
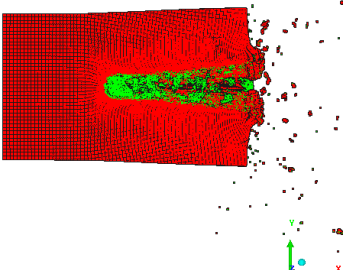
Rotational speed (rpm)	Liner type CU-OFHC2 (Copper)	Liner type STEEL 4340 (Steel)
0	<p>Material Location</p> <ul style="list-style-type: none"> AL 6061-T6 CU-OFHC2 COMP B STEEL 1006  <p>admodel Cycle 2882 Time 1.000E-01 ms</p>	<p>Material Location</p> <ul style="list-style-type: none"> AL 6061-T6 STEEL 4340 COMP B STEEL 1006  <p>admodel Cycle 4112 Time 1.000E-01 ms</p>
2000	<p>Material Location</p> <ul style="list-style-type: none"> AL 6061-T6 CU-OFHC2 COMP B STEEL 1006  <p>admodel Cycle 3467 Time 1.000E-01 ms</p>	<p>Material Location</p> <ul style="list-style-type: none"> AL 6061-T6 STEEL 4340 COMP B STEEL 1006  <p>admodel Cycle 3255 Time 1.000E-01 ms</p>
4000	<p>Material Location</p> <ul style="list-style-type: none"> AL 6061-T6 CU-OFHC2 COMP B STEEL 1006  <p>admodel Cycle 2725 Time 1.000E-01 ms</p>	<p>Material Location</p> <ul style="list-style-type: none"> AL 6061-T6 STEEL 4340 COMP B STEEL 1006  <p>admodel Cycle 4233 Time 1.000E-01 ms</p>
6000	<p>Material Location</p> <ul style="list-style-type: none"> AL 6061-T6 CU-OFHC2 COMP B STEEL 1006  <p>admodel Cycle 3537 Time 1.000E-01 ms</p>	<p>Material Location</p> <ul style="list-style-type: none"> AL 6061-T6 STEEL 4340 COMP B STEEL 1006  <p>admodel Cycle 3568 Time 1.000E-01 ms</p>

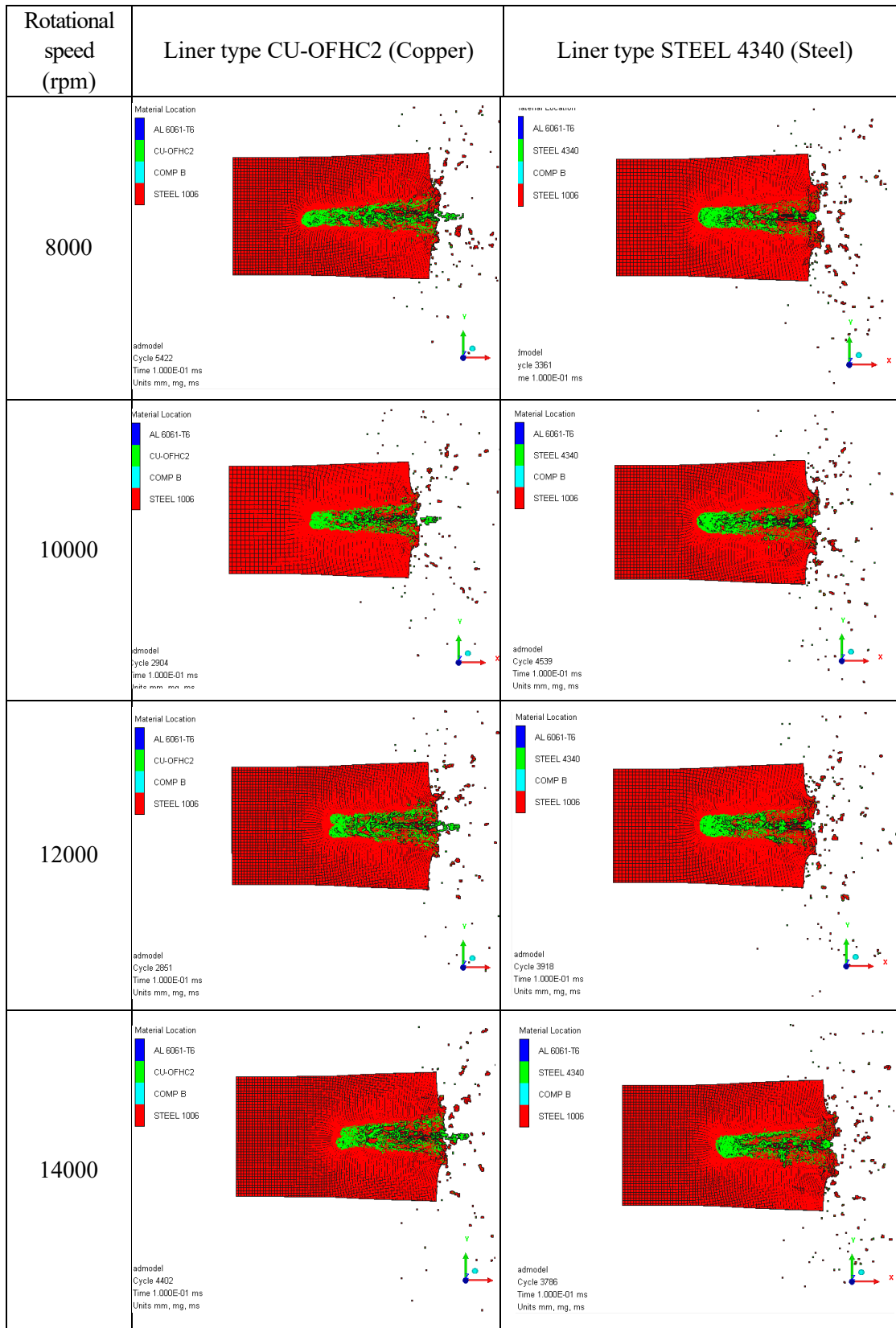

From the simulation results with two types of liners, it can be observed that: when the warhead is not rotating, the jet diameter is concentrated and narrower. when the warhead rotates, the jet diameter becomes larger. The results of the penetration depth of the target corresponding to the rotational speeds of the two types of liners are provided in table 5. Note: The penetration depth results may have some deviation compared to the length measurements obtained on the Ansys software.

Table 5. Penetration depth of steel for the shaped charge warhead with different liner types.

Rotational speed ω (rpm)	Penetration depth b (mm)		Reduction in penetration depth of the steel liner compared to the copper liner (%)
	Liner type CU-OFHC2	Liner type STEEL 4340	
0	80	62	22.5
2000	78	61	21.8
4000	76	61	19.7
6000	72	59	18.0
8000	65	58	10.8
10000	56	57	- 1.8
12000	51	55	- 7.8
14000	50	54	- 8.0

It can be observed that the penetration depth of the projectile decreases as the spin rate increases, which is consistent with the theory of projectile effectiveness. Compared to non-rotating projectiles, the penetration depth of projectiles spinning at rotational speeds of 2000 rpm, 4000 rpm, 6000 rpm, 8000 rpm, 10000 rpm, 12000 rpm, and 14000 rpm with a copper-lined cone decreases by 2,5%, 5%, 10%, 19%, 30%, 36%, and 37,5%, respectively, while with a steel-lined cone, it decreases by 1.6%, 1.6%, 5%, 6.5%, 8%, 11%, and 13%, respectively. Thus, the steel penetration depth of the copper-lined cone decreases more significantly than that of the steel-lined cone as the spin rate increases. The reduction in penetration depth of the steel-lined cone compared to the copper-lined cone at spin rates of 0 rpm, 2000 rpm, 4000 rpm, 6000 rpm, 8000 rpm, 10000 rpm, 12000 rpm, and 14000 rpm is 22.5%, 21.8%, 19.7%, 18%, 10.8%, -1.8%, -7.8%, and -8%, respectively. The simulation results for the non-rotating copper lined cone closely match the actual test results of the 40 mm shaped charge round, with a penetration depth of approximately 80 mm.

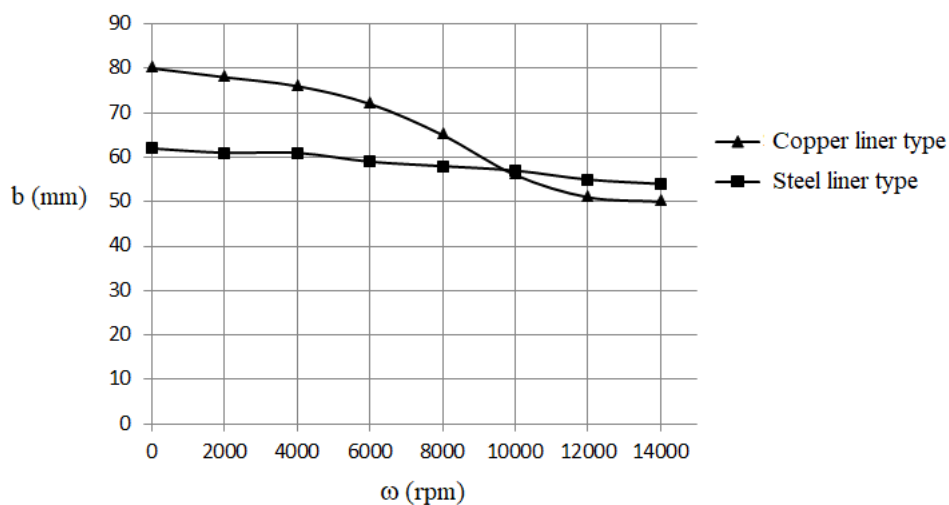

Figure 2. Penetration depth as a function of spin rate for copper- and steel-lined cones.

From the results in table 5 and the graph in figure 2, it can be observed that with different liner materials and the same rotational velocity, the copper liner provides better penetration depth than the steel liner. However, at rotational velocities of approximately 10000 rpm and above, the penetration capability of both liners becomes nearly identical, with the steel liner even exhibiting superior performance in some cases. This result aligns with the theory of projectile effectiveness - when the projectile's rotational velocity is high (around $(10...15) \cdot 10^3$ rpm), the penetration depth of a copper liner is not significantly greater than that of a steel-lined projectile [12].

4. CONCLUSIONS

The research results indicate that as the rotational velocity around the axis increases, penetration effectiveness decreases. The copper liner exhibits greater penetration capability than the steel liner; however, when the rotational velocity exceeds approximately 10000 rpm, the penetration depth of the copper liner is not significantly greater than that of the steel-lined projectile and may even be lower. Based on this finding, for 40 mm shaped charge projectiles with high rotational speeds (above 8000 rpm), a steel liner should be used to enhance penetration effectiveness. This calculation method can also be applied to the design of liners for other shaped charge projectiles with high rotational speeds, as it aligns with theoretical principles.

The 3D simulation results of shaped charge projectiles using the SPH method in Ansys Autodyn are fully consistent with the theoretical calculations of shaped charge effectiveness. This simulation method can be applied to further optimize the design of rotating shaped charge projectiles.

REFERENCES

- [1]. ANSYS, Inc. "ANSYS Workbench User's Guide", (2011).
- [2]. A.V. Babkin, S.S. Rassokha, S.V. Ladov, "Calculation method for functionality of the rotating shaped charges". *Oboronnaya tekhnika*, no. 1-2, pp. 23-30, (2010) (in Russian).
- [3]. A.S. Steshin, A.V. Babkin, "Design Technique for Calculating Functional Parameters of a Rotating Shaped Charge with Preliminary Heated Liner". *Вестник МГТУ им. Н.Э. Баумана. Сер. Естественные науки*, ISSN: 1812-3368, № 1, pp. 61-70, (2020).
- [4]. Dobratz B.M & Crawford P.C. UCRL-52997 Rev. "LLNL Explosives Handbook", (1985).
- [5]. K. Naeem, A. Hussain, S. Abbas, "A Review of Shaped Charge Variables for its Optimum Performance". *Engineering, Technology & Applied Science Research* Vol. 9, No. 6, 4917-4924, (2019).
- [6]. L.B. Lucy. "A numerical approach to the testing of the fission hypothesis". *Astron. J.* 82: 1013-1024. Bibcode:1977AJ.82.1013L. doi:10.1086/112164, (1977).
- [7]. L.D. Libersky; A.G. Petschek; A.G. Carney; T.C. Hipp; J.R. Allahdadi; F.A. High. "Strain Lagrangian hydrodynamics: a three-dimensional SPH code for dynamic material response". *J. Comput. Phys.* 109 (1): 67-75, (1993). doi:10.1006/jcph.1993.1199.
- [8]. R.A. Gingold; J.J. Monaghan. "Smoothed particle hydrodynamics: theory and application to non-spherical stars". *Mon. Not. R. Astron. Soc.* 181 (3): 375-89, (1977). doi:10.1093/mnras/181.3.375.
- [9]. S.S. Rassokha. "Numerical Simulation of Jet Formation from a Rotating Shaped Charge". *Combust Explos Shock Waves* 60, pp. 811-818, (2024).
- [10]. V. Minh Do, M. Thai Le, X. Son Bui, H. Nguyen Pham and P. Linh Nguyen, "Influence of Wave Shaper Position on Jet Formation and Penetration Depth", *Advances in Military Technology*, 15(2), pp. 355-364, (2020), DOI 10.3849/aimt.01385
- [11]. V. V. Silvestrov, N. N. Gorshkov, "Effect of strain rate on the tensile strength of copper shaped charge jet". *Proceedings of the conference of the American Physical Society topical group on shock compression of condensed matter. AIP Conference Proceedings, Volume 370*, pp. 1233-1236, (1996).
- [12]. А.А. Плющ, "Физические основы устройства ракетно-артиллерийского вооружения. Боенприпасы", Пензенский артиллерийский инженерный институт, (2014).
- [13]. И.В. Минин, О.В. Минин, "Кумулятивные заряды", Сибирская государственная геодезическая академия, (2013).

TÓM TẮT

Nghiên cứu ảnh hưởng của vật liệu phễu lót đạn xuyên lõm quay đến chiều sâu xuyên bằng phương pháp mô phỏng số SPH

Bài báo nghiên cứu ảnh hưởng của vật liệu phễu lót đến uy lực đạn xuyên lõm quay. Nhóm tác giả đã sử dụng mô phỏng 3D bằng phương pháp không lưới SPH trên phần mềm Ansys Autodyn để khảo sát ảnh hưởng của vật liệu phễu lót đạn xuyên lõm quay. Đối tượng nghiên cứu là đầu đạn xuyên lõm cỡ 40 mm, vật liệu làm phễu lót sử dụng hai phương án là vật liệu đồng và vật liệu thép. Mô phỏng số tiến hành với tốc độ quay quanh trục đối xứng của đạn ở các vận tốc khác nhau: không quay, 2000 vòng/phút, 4000 vòng/phút, 6000 vòng/phút, 8000 vòng/phút, 10000 vòng/phút, 12000 vòng/phút và 14000 vòng/phút. Kết quả mô phỏng số cho thấy vận tốc quay càng lớn, chiều sâu xuyên thép càng nhỏ, phễu bằng đồng có uy lực xuyên thép lớn hơn phễu bằng thép, tuy nhiên khi vận tốc quay đến 10.000 vòng/phút thì chiều xuyên sâu thép của phễu lót bằng đồng không lớn hơn hẳn đạn phễu lót thép. Phương pháp nghiên cứu này có thể được sử dụng để tối ưu thiết kế kết cấu đạn lõm quay.

Từ khóa: Đạn xuyên lõm quay 40 mm; Uy lực đạn xuyên lõm; Phương pháp SPH.