

## Design of a weaponized drone munitions system with a bomb simulation using PVC material

Rudy Agus Gemilang Gultom<sup>1</sup>, Syachrul Arief<sup>2\*</sup>, Muhammad Hanifudin Al Fadli<sup>1</sup>

<sup>1</sup>Faculty of Defense Science and Technology Republic Indonesian Defense University;

<sup>2</sup>Geospatial Information Authority of Indonesia.

\*Corresponding author: syachrul.arief@big.go.id

Received 07 Aug. 2023; Revised 04 Oct. 2023; Accepted 10 Nov. 2023; Published 25 Nov. 2023.

DOI: <https://doi.org/10.54939/1859-1043.j.mst.91.2023.73-84>

### ABSTRACT

*The advancement of drone technology in the 21st century has experienced tremendous progress. Drones are now utilized not only for military purposes but also in commercial applications, featuring sophisticated systems such as waypoint navigation and automatic camera tracking, and even as a tool for teaching natural sciences to students. The objective of this research is to design a multifunctional armed drone system capable of performing various tasks, such as mapping, reconnaissance, and attack. The outcome of this research is a prototype of an armed drone based on the DJI Matrice 600, equipped with an ammunition release system that can drop payloads at predetermined waypoint coordinates. The ammunition release system has been tested in various configurations, with data from 10 tests indicating that 6 ammunitions exploded, while 4 others failed to explode. The failure of the ammunition to explode was due to the drone's proximity to the target and the uneven terrain of the target area, which hindered the proper functioning of the detonation trigger system.*

**Keywords:** Weaponized Drone; DJI Matrice 600; Waypoint.

### 1. INTRODUCTION

Weaponized drones, unmanned aircraft that have been modified to carry weapons or other devices for military purposes (Austin, 2016), have become one of the most advanced technologies in the field of national security and defense (Boyle, 2018). The use of weaponized drones has been a heated debate due to their ability to carry weapons with high accuracy and exploit areas that are difficult for humans to reach (Horowitz & Scharre, 2015). However, using weaponized drones is not limited to military and national security interests. Weaponized drones can also be used as an engaging and interactive means of learning natural sciences (Huang et al., 2018). Through this approach, students can learn how technology can be applied in the field of aviation and the development of complex control systems, as well as their impacts on the environment and wildlife (Watts, 2016).

One example of using weaponized drones as a means of learning natural sciences is by simulating bombs made of PVC material (Karimov et al., 2020). In this learning, students can learn how to create bomb simulations made of PVC material, which can be used to test the drone's ability to carry and drop bombs (Abdul Kadir et al., 2018). This learning can help students understand how weaponized drones work and how remote control technology operates the drone (Clothier et al., 2015). Several previous studies have explored critical aspects of the development and use of armed drones (Austin, 2016; Boyle, 2018). One significant finding is the importance of choosing the right material to mimic the properties of real bombs in simulations (Karimov et al., 2020). PVC material, used in this study, has been proven to have advantages in terms of

durability, lightness, and ease of shaping (Abdul Kadir et al., 2018). Additionally, PVC has a lower production cost and is easier to recycle than other materials such as metal or composites (Shah et al., 2015). Considering these factors, this research focuses on the use of PVC in bomb simulations to create a realistic, safe, and economic system.

To ensure the effectiveness and safety of the designed weaponized drone munition system, this research will adopt a rigorous methodology and include various tests (Clothier et al., 2015). This includes aerodynamic testing to measure the performance of the drone and PVC bomb simulations in various environmental conditions, as well as testing the reliability of electronic and mechanical components (Huang et al., 2018). Furthermore, this research will pay attention to ethics and security in the use of weaponized drone technology, referring to existing guidelines such as the Geneva Convention and international humanitarian law (International Committee of the Red Cross, 2017). Through this comprehensive approach, this research is expected to provide valuable insights to the scientific community and society at large about the potential and challenges associated with the use of weaponized drone systems.

The importance of this research lies in the urgent need to understand and manage the risks associated with the use of armed drones in various situations (Watts, 2016). With the increasing use of drones in the military and security fields, there are concerns about the possible misuse of technology and its impact on civilians (Murray et al., 2021). This research aims to explore the potential of safe and effective weaponized drone systems, as well as provide a learning platform that encourages critical thinking about the ethics and responsibilities associated with their use (Horowitz & Scharre, 2015). By understanding the workings and limitations of this technology through safe and controlled simulations, researchers, decision-makers, and the general public can make more informed decisions about the implementation and regulation of weaponized drone technology

## **2. METHODS**

The design in this research utilizes an experimental design and development approach, where the design and development activities are divided into two stages: hardware design and electronic system design. Experiments are also conducted with partial testing of the equipment and overall testing.

### **Hardware Design**

The design process involves creating a munition system and bracket mount to be installed on the Matrice 600 drone. The munition is made of PVC pipe with a diameter of 2.5 inches and a length of 20 cm. At the tail end, four fins are installed to serve as stabilizers during free-fall motion.

The munition bracket functions as the mounting point for the munitions on the Matrice 600 drone. The bracket is made from 1-inch hollow aluminum and is capable of carrying two munitions simultaneously. The aluminum pipe connections use nylon plastic joints, allowing the munition bracket frame to be mounted with precision.

A servo motor actuator is installed at the front as the release mechanism for the munitions from the Matrice 600 drone. Munitions are attached to the bracket using two hooks. The locking system on the bracket keeps the munitions in place before the release command is given from the control system. The bracket system can be attached to the

drone using cable ties, making it easily removable for convenient maintenance. The installation of the bracket on the drone is shown in figure 1.

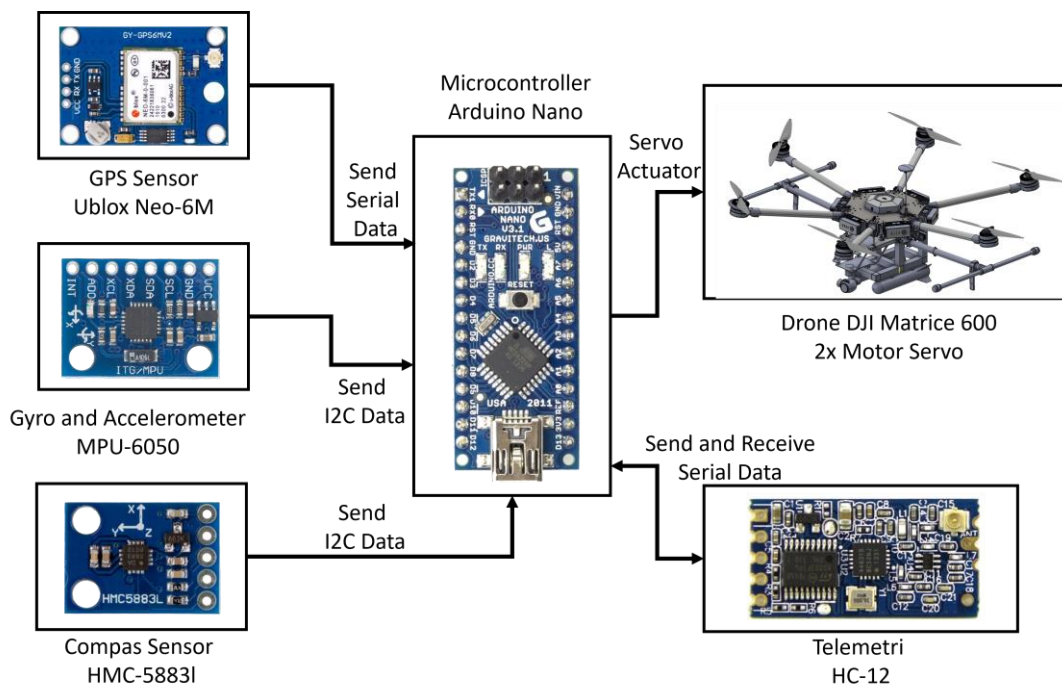

**Figure 1.** (a) (b) Mounting design of the ammunition on the bracket of the drone.

### Electronic System Design

The electronic system of the weaponized multirole drone is designed to read the drone's coordinate position while flying, access gyroscope and accelerometer sensors, and calculate the timing for dropping munitions. The drone's parameters are then transmitted to the ground control station (GCS) using 433 MHz telemetry.

The electronic system is designed using an Arduino Nano microcontroller. The electronic system design is shown in figure 2.

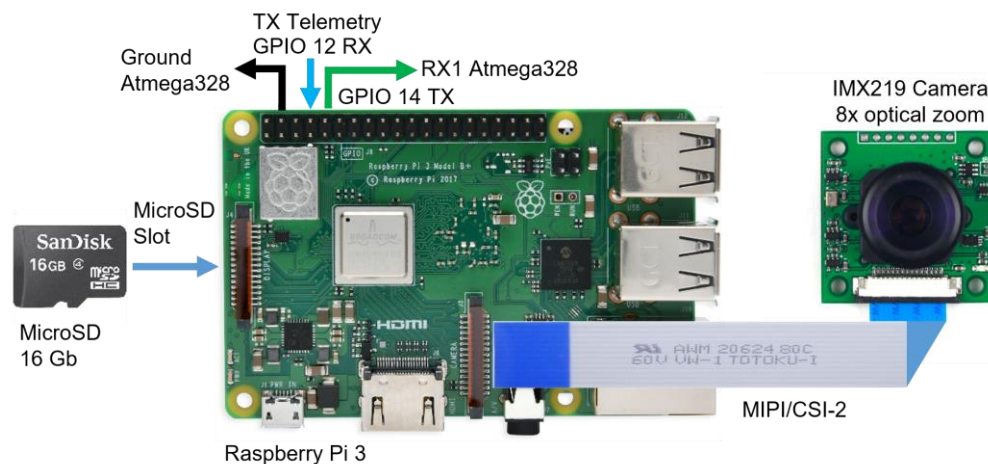

**Figure 2.** Schematic of the Arduino Nano microcontroller.

The communication protocols used are the Inter-Integrated Circuit (I2C) protocol and the Universal Serial Asynchronous Receive and Transmit (USART) serial

communication. The GPS sensor is used to get latitude and longitude data using Serial USART communication while MPU-6050 and HMC-58831 sensor are used to get roll, pitch and yaw data using I2C communication.

The Matrice 600 drone is equipped with Raspberry Pi-based image processing hardware. The Raspberry Pi system is used to access the IMX219 camera. The Raspberry Pi electronic design is shown in figure 3.



**Figure 3.** Schematic of the Raspberry Pi electronic system.

Raspberry Pi is a mini-computer running on the Linux Raspbian operating system. This system reads images captured by the IMX219 camera using the MIPI/CSI-2 protocol. The tracking system uses an artificial intelligence algorithm, enabling it to classify the images obtained and, in real time, track moving targets.

Haversine formula is used to conduct an auto-release system. The formula is used to calculate the distance between the drone and the munition release point in GPS coordinate. If the calculated distance is less than 1 meter, the GPS auto release system will turn on and munition will fall to the target. The Haversine formula that used to measure the distance is shown as follows

$$a = \sin^2 (\Delta\varphi/2) + \cos \varphi_1 \cdot \cos \varphi_2 \cdot \sin^2 (\Delta\lambda/2)$$

$$c = 2 \cdot \arctan (\sqrt{a}, \sqrt{1-a})$$

$$\text{distance} = c \cdot \text{Earth radius}$$

where  $\varphi$  is the latitude position and  $\lambda$  is the longitude position.

### 3. RESULTS AND DISCUSSION

#### Munition System Creation

The munition system is made using PVC pipes with a diameter of 2 inches. The munition fabrication technique utilizes a hot stamping process, where heating the pipe is required to form the desired munition shape. As the pipe becomes pliable due to heating, it can be molded using a previously created mold to achieve the desired shape. The pipe heating process is carried out using a butane gas stove.

Once the pipe is molded into the desired shape, the remaining pipe needs to be cut using a mini grinder, resulting in four munition components: the nose cone, body, fins,

and end cap. To assemble these parts, the cut pipe segments are joined together using Alteco adhesive glue. Once formed, the parts of the ammunition are put together to form the mechanics of the ammunition according to figure 4.

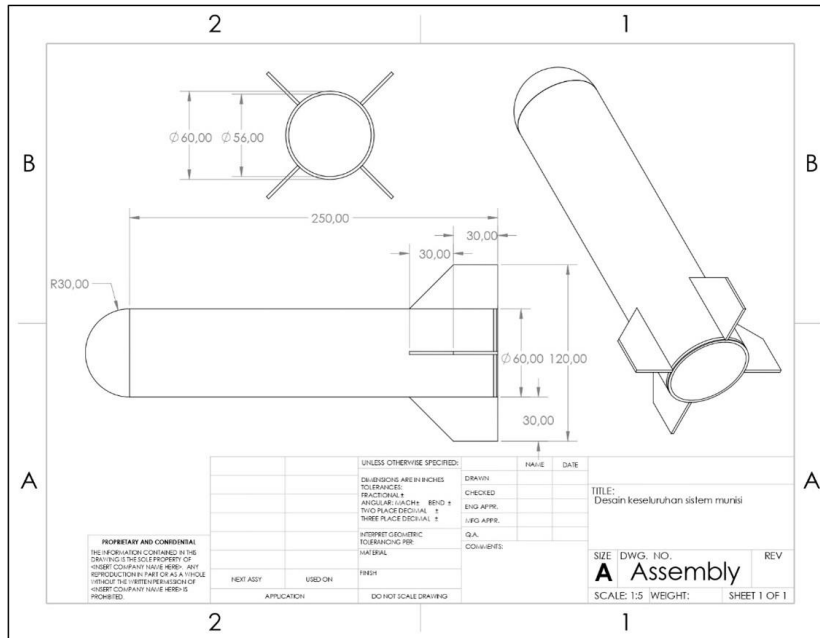

(a)



(b)

**Figure 4.** (a) Design of the ammunition system assembly and (b) Data acquisition munition, vertical munition and horizontal munition (from left to right).

There are three types of munitions created in this study, namely:

*a. Horizontal configuration munition system*

The horizontal configuration munition system is created according to the dimensions shown in figure 6, where the munition placement process on the drone is mounted horizontally. An impact fuze system is added to the front of the munition, so when the munition is dropped from the drone and the impact fuze hits the target, the munition will explode. In the horizontal configuration, the DJI Matrice 600 drone can only carry two munitions.

*b. Vertical configuration munition system*

In the vertical configuration munition system, the munition mechanics are shortened by 8 cm so that the impact fuze installed at the front does not touch the ground when mounted on the drone. With the vertical configuration, the DJI Matrice 600 drone can carry up to four munitions.

*c. Munition data acquisition system*

The munition data acquisition system is created as a munition platform used to analyze the movement of the munition when dropped. The munition is equipped with a payload consisting of a microcontroller and inertial sensors, including a gyroscope, accelerometer, and magnetometer.

**Inertial Sensor Testing in the Field for Ammunition**

Ammunition equipped with inertial sensors was flown using a DJI Matrice 600 drone. The ammunition was then dropped from the drone at an altitude of 50-60 meters above ground level. The falling ammunition's dynamic movements were measured using a microcontroller through inertial sensors. Inertial sensor readings were then transmitted to the drone pilot using 433MHz telemetry.

The ammunition release system used an interrupt signal to measure the duration from when the ammunition was dropped until it hit the target. To prevent damage to the ammunition system upon impact, it was dropped onto a 4x5 meter net with a 95% coverage rate. The drone system also recorded the falling ammunition's movement using a camera facing the target area. Each ammunition piece was dropped onto the net, yielding five sets of test data. Field test results for Ammunition A are shown in figure 5.

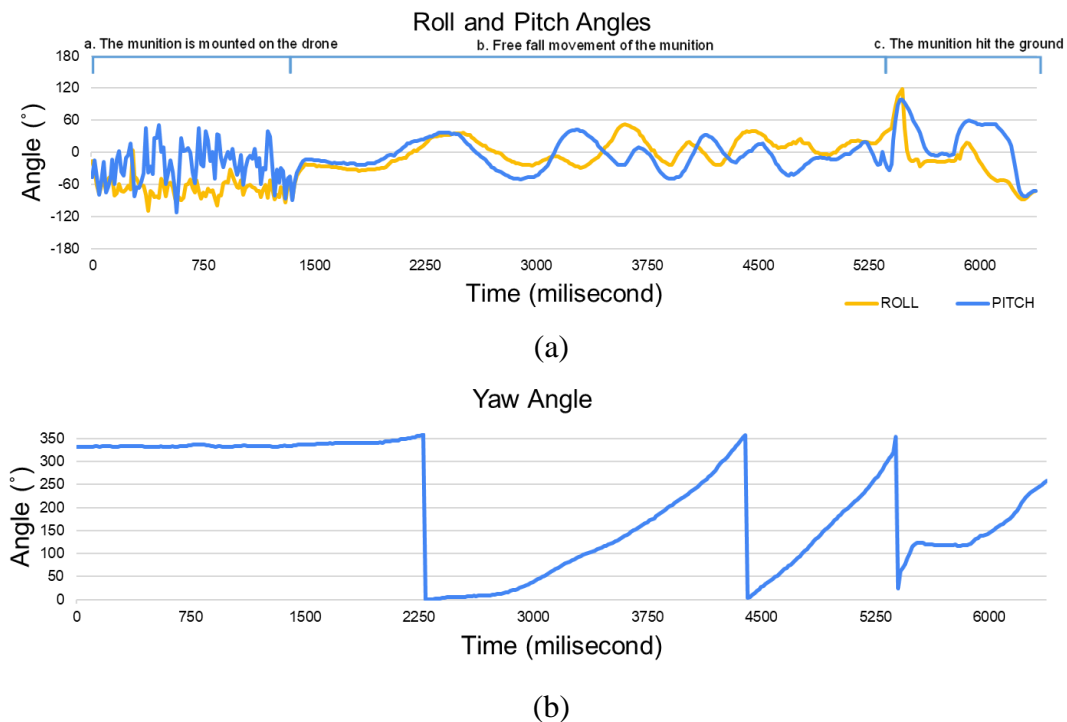

**Figure 5.** (a) Graph of Ammunition A's roll and pitch axes movements and (b) Ammunition A's yaw axis movements.

Ammunition A was dropped from a height of 62 meters with an average wind speed of 4.5 m/s. Field testing of Ammunition A yielded data showing a falling duration of 3.72 seconds from the drone to impact. The ammunition struck the target at 5.07 seconds with a final roll angle of  $-7^\circ$ , a pitch angle of  $13^\circ$ , and a yaw angle of  $198^\circ$ . The ammunition experienced several oscillating movements in the pitch and roll axes, but these oscillations decreased over time. The ammunition made two rotations around the yaw axis from the moment it was dropped until it struck the target.

Ammunition A experienced seven oscillating movements in the roll axis and seven oscillating movements in the pitch axis. The maximum roll angle was  $40^\circ$  at 3.28 seconds after release, and the maximum pitch angle was  $47^\circ$  at 3.54 seconds after release. The ammunition system successfully hit the net at a radius of 1.2 meters from the center of the drone camera's line of sight.

Subsequently, Ammunition B was tested. Field test results for Ammunition B are shown in figure 6.

Ammunition B was dropped from a height of 61 meters with an average wind speed of 6.4 m/s. Field testing of Ammunition B yielded data showing a falling duration of 3.54 seconds from the drone to impact. The ammunition struck the target at 4.23 seconds with a final roll angle of  $6^\circ$ , a pitch angle of  $7^\circ$ , and a yaw angle of  $47^\circ$ . The ammunition experienced several oscillating movements in the pitch and roll axes, but these oscillations decreased over time. The ammunition made one rotations around the yaw axis from the moment it was dropped until it struck the target.

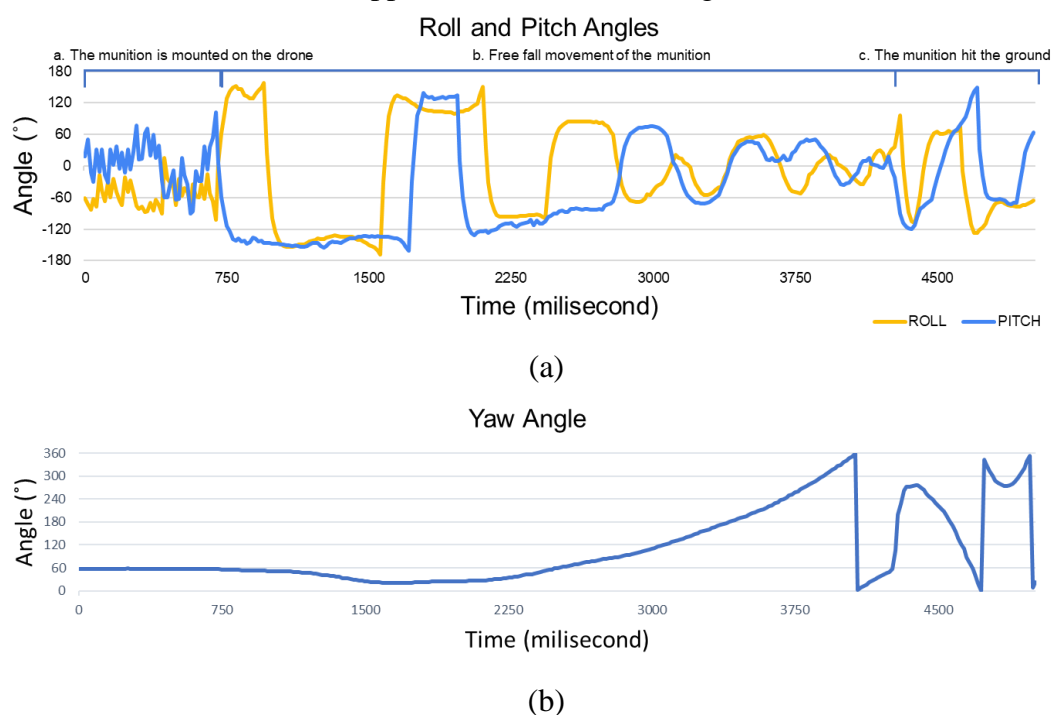
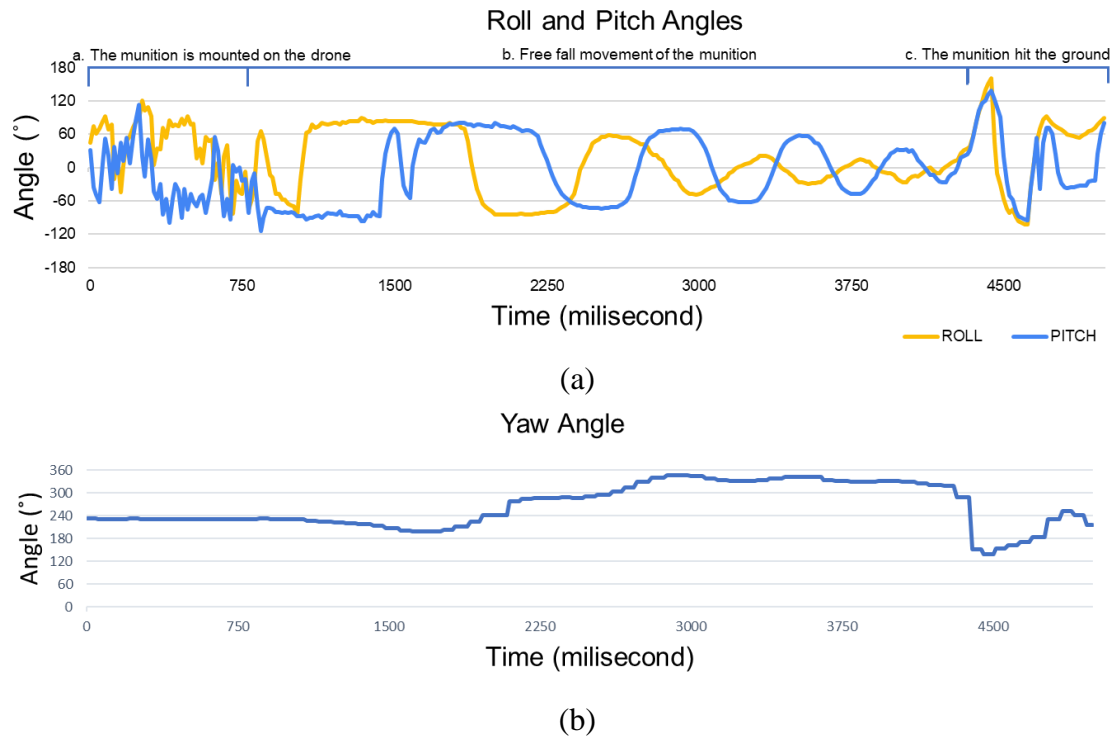

**Figure 6.** (a) Graph of munition B movement data on the roll and pitch axes and (b) munition B movement on the yaw axis.

Ammunition B experienced seven oscillating movements in the roll axis and five oscillating movements in the pitch axis. There is an Euler angle singularity when the roll

angle and the pitch angle approach  $90^\circ$  occurring between 0.72 and 2.12 seconds. The ammunition system successfully hit the net at a radius of 1.52 meters from the center of the drone camera's line of sight.

Subsequently, Ammunition C was tested. Field test results for Ammunition C are shown in figure 7.



**Figure 7.** (a) Graph of munition C movement data on the roll and pitch axes and (b) munition C movement on the yaw axis.

The munition was dropped from a height of 58 meters with an average wind speed of 5.4m/s. From the field test of munition C, it was found that the duration of the munition drop from the drone to impact the target was 3.45 seconds. The munition hit the target at 4.26 seconds with a final roll angle of  $12^\circ$ , a pitch angle of  $-9^\circ$ , and a yaw angle of  $319^\circ$ . The munition experienced several oscillation movements on the pitch and roll axes, but the oscillation movements decreased over time. The munition did not experience any rotational movement on the yaw axis from the moment it was dropped from the drone until it hit the target.

Munition C experienced 4 oscillation movements on the roll axis and 5 oscillation movements on the pitch axis, with a maximum roll axis inclination of  $88^\circ$  at 1.36 seconds after being dropped and a maximum pitch axis inclination of  $80^\circ$  at 1.99 seconds after being dropped. The munition system successfully hit the target net with a radius distance of 0.85 meters from the center of the drone camera's line of sight. Subsequently, munition D was tested. The results of the field test for munition D are shown in figure 8.

The munition was dropped from a height of 64 meters with an average wind speed of 4.6m/s. From the field test of munition D, it was found that the duration of the munition drop from the drone to impact the target was 3.70 seconds. The munition hit the target at

4.45 seconds with a final roll angle of  $5^\circ$ , a pitch angle of  $-7^\circ$ , and a yaw angle of  $42^\circ$ . The munition experienced several oscillation movements on the pitch and roll axes, but the oscillation movements decreased over time. The munition did not experience any rotational movement on the yaw axis from the moment it was dropped from the drone until it hit the target.

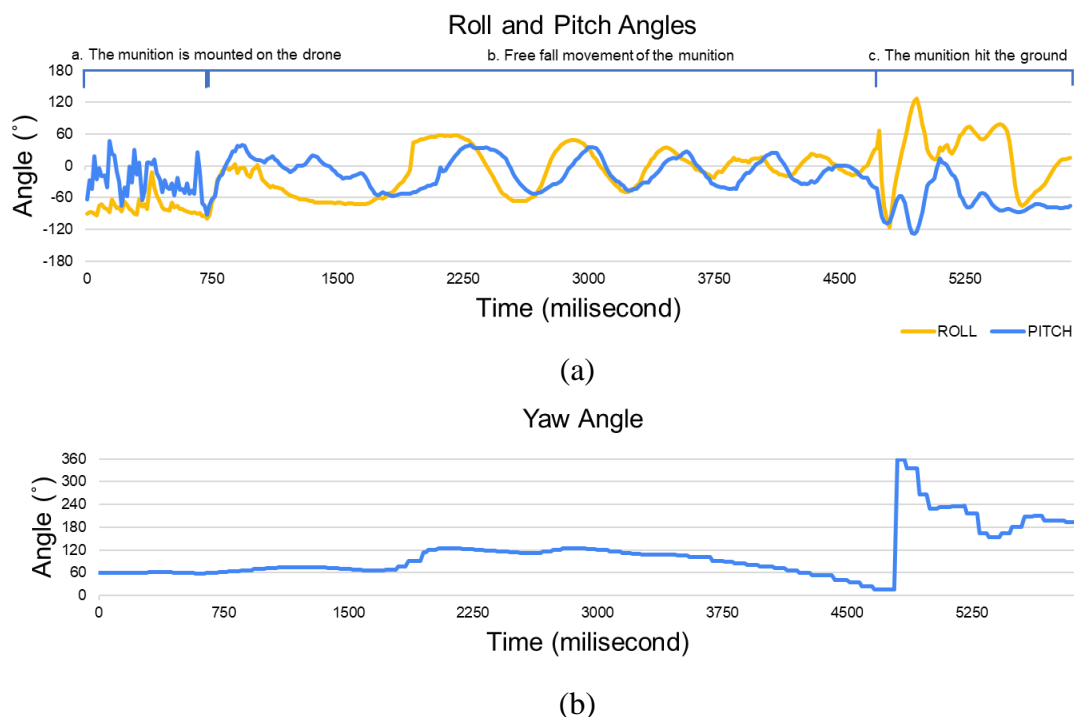

**Figure 8.** (a) Graph of munition D movement data on the roll and pitch axes and (b) munition D yaw axis movement.

Munition D experienced 6 oscillations in the roll axis and 6 oscillations in the pitch axis, with a maximum roll angle of  $58^\circ$  at 2.1 seconds after being dropped and a maximum pitch angle of  $38^\circ$  at 0.98 seconds after being dropped. The munition system successfully hit the target net with a radial distance of 0.50 meters from the center of the drone camera's line of sight. Next, munition E was tested. The field test results for munition E are shown in figure 9.

The munition was dropped from a height of 59 meters with an average wind speed of 4.8m/s. The munition E's data shows the munition took 3.70 seconds to fall from the drone to impact the target. The munition hit the target at the 4.45-second mark with a final roll angle of  $5^\circ$ , a pitch angle of  $-7^\circ$ , and yaw angle of  $42^\circ$ . The munition experienced several oscillations in the pitch and roll axes, but the oscillations decreased as time increased. The munition did not rotate in the yaw axis from the time it was dropped from the drone until it hit the target.

During the drop test of munition E, the Euler angle was singular when the calculated roll and pitch angles approached  $90^\circ$ , occurring between 0.61 and 2.84 seconds. Outside of the singularity period, munition E experienced 4 oscillations in the roll axis and 3 oscillations in the pitch axis. The munition system successfully hit the target net with a radial distance of 0.6 meters from the center of the drone camera's line of sight.

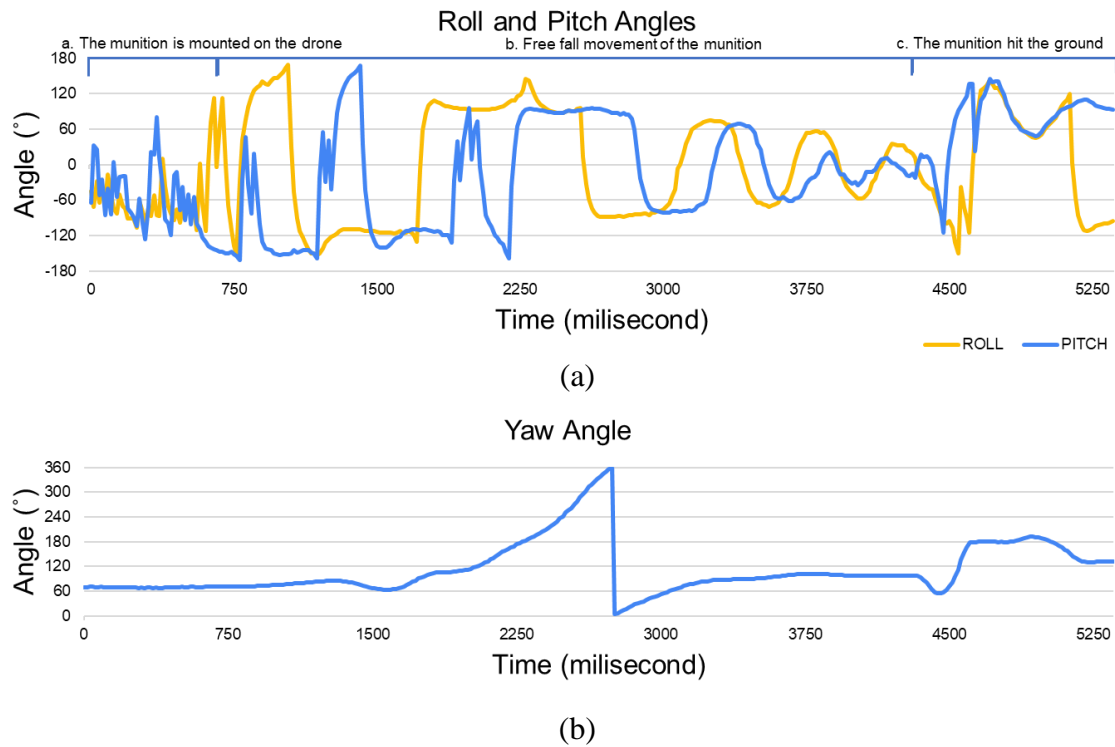

Figure 9. (a) Graph of munition E's movement data on the roll and pitch axes and (b) munition E's yaw axis movement.

Overall, the field tests of munitions equipped with inertial sensors produced the data shown in table 1.

Table 1. Field test results for munitions with inertial sensors.

No	Munition	Final Position (°)			Munition impact distance from line of sight (m)	Number of Oscillations			Note.	GPS Auto release
		Roll	Pitch	Yaw		Roll	Pitch	Yaw		
1	A	-7	13	198	1.2	7	7	2		Yes
2	B	6	7	47	1.52	7	5	1	Singl.	Yes
3	C	12	-9	319	0.85	4	5	-		Yes
4	D	5	-7	42	0.5	6	6	-		Yes
5	E	19	-15	97	0.6	5	6	1	Singl.	Yes

From the field tests of the munition system equipped with inertial sensors, it was found that the munition system with a center of mass 12 cm from the munition's nose, when dropped from a height of  $60 \pm 2$  meters with an average wind speed of 5.14 m/s, would hit the target with an average munition impact distance from the line of sight of 0.93 meters. The average position of the munition when hitting the target was at a roll angle of  $9.8^\circ$ , a pitch angle of  $10.2^\circ$ , and experienced a rotation of  $288^\circ$ .

#### 4. CONCLUSIONS

The DJI Matrice 600 system is capable of carrying up to four munitions equipped with explosive materials. The munition system can also be integrated with various inertial sensors, such as gyroscopes, accelerometers, and magnetometers, allowing for the transmission of munition attitude and movement data when dropped from the drone. From the munition drop tests equipped with inertial sensors, it was found that on average, the munition system with the center of mass located 12 cm from the munition's nose, when dropped from a height of  $60\pm 2$  meters with average wind conditions of 5.14 m/s, would hit the target with an average distance of 0.93 meters from the aiming point.

The munition's position when hitting the target was on average at a roll angle of  $9.8^\circ$ , a pitch angle of  $10.2^\circ$ , and experienced a rotation of  $288^\circ$ . During the live demo at Indo Defense 2022, out of 12 dropped munitions equipped with explosives, eight munitions successfully detonated upon impact, and four did not explode. Two of the unexploded munitions were due to uneven target surfaces, causing the contact sensors to malfunction.

The other two unexploded munitions resulted from safety arming not being disengaged by the drone operator. The safety arming system developed successfully prevented the munitions from detonating even when dropped from a height of 20 meters.

This weaponized drone design conclusion can be linked to the learning of natural sciences, as the development and testing process involves a deep understanding of physics, aerodynamics, and engineering principles. The study also provides valuable insights into real-world applications of science, technology, engineering, and mathematics (STEM) education, demonstrating the significance of these fields in the development of advanced defense systems

#### REFERENCES

- [1]. Abdul Kadir, A., Sapuan, S. M., Zainudin, E. S., & Jaafar, C. N. A. "Mechanical properties of polyvinyl chloride (PVC) composites filled with kenaf core and/or kenaf fiber". *Fibers and Polymers*, 19(1), 148-155, (2018).
- [2]. Austin, R. "Unmanned aircraft systems: UAVs design, development and deployment". John Wiley & Sons, (2016).
- [3]. Boyle, M. J. "The race for drones: The evolution of the drone market and the need for a regulatory framework". *Computer Law & Security Review*, 34(4), 772-785, (2018).
- [4]. Clothier, R. A., Greer, D. A., Greer, D. G., & Mehta, A. M. "Risk perception and the public acceptance of drones". *Risk Analysis*, 35(6), 1167-1183, (2015).
- [5]. Crootof, R. "The killer robots are here: Legal and policy implications". *Cardozo L. Rev.*, 36, 1837, (2016).
- [6]. Horowitz, M. C., & Scharre, P. "The moral and legal imperatives of weaponized drones". *The National Interest*, 143, 29-39, (2015).
- [7]. Huang, Y., Nascimento, D. V., & Ratti, C. "An analytical model for the environmental design of drone systems". *Energy and Buildings*, 158, 1423-1436, (2018).
- [8]. International Committee of the Red Cross. "Drones and the law of armed conflicts", (2017).
- [9]. Karimov, M., Samadov, M., Abdukadirov, S., & Rakhmonov, R. "Simulation of drone-borne radar system for detection and identification of objects". *International Journal of Advanced Computer Science and Applications*, 11(3), 220-225, (2020).

- [10]. Murray, M. B., McGreevy, J. P., & Russell, S. M. “The ethical implications of military drone use”. In Ethics and the Future of Spying (pp. 134-150). Routledge, (2021).
- [11]. Watts, B. D. “The maturing revolution in military affairs”. Center for Strategic and Budgetary Assessments, (2016).

### TÓM TẮT

#### Thiết kế hệ thống vũ khí đạn cho máy bay không người lái vũ trang với mô phỏng bom vật liệu PVC

Sự phát triển của công nghệ máy bay không người lái (drone) trong thế kỷ 21 đã có những tiến bộ vượt bậc. Ngày nay, drone không chỉ được sử dụng cho mục đích quân sự mà còn trong các ứng dụng thương mại, bao gồm các hệ thống phức tạp như điều hướng theo lộ trình đặt trước và giám sát camera tự động, thậm chí còn làm công cụ giảng dạy khoa học tự nhiên cho học sinh. Mục tiêu của nghiên cứu này là thiết kế một hệ thống drone vũ trang đa chức năng có khả năng thực hiện nhiều nhiệm vụ khác nhau, như lập bản đồ, trinh sát và tấn công. Kết quả nghiên cứu này là đưa ra một mẫu drone vũ trang dựa trên nền tảng Matrice 600 của DJI, được trang bị hệ thống thả đạn có khả năng tấn công vào các điểm có tọa độ đặt trước. Hệ thống thả đạn đã được thử nghiệm trong nhiều kịch bản khác nhau, số liệu từ 10 thử nghiệm cho thấy 6 lần đạn nổ, và 4 lần đạn không nổ. Nguyên nhân của việc đạn không nổ là do khoảng cách giữa máy bay và mục tiêu quá gần và do địa hình khu vực mục tiêu gồ ghề khiến cho hệ thống kích nổ không hoạt động được.

**Từ khóa:** Máy bay không người lái vũ trang; DJI Matrice 600; Điểm đặt trước.